

LOAD CALCULATION CHART

CONDUIT APPLICATIONS USING RIGID STEEL (HEAVY DUTY) CONDUIT

HOW TO USE THE CHART

APPLICATION: Choose the appropriate conduit size and the amount of conductor contained in the conduit. The chart indicates the weight per foot of conduit. To choose the proper number of pipe supports, simply divide the cumulative weight per foot by the maximum capacity of the support. (Refer to the submittal sheets for the maximum loading capacities.)

EXAMPLE #1: If you have a 1/2" Conduit which is filled 75% - 100% with conductor and two 1" Conduits that are filled 25% - 50% with conductor, you have $1.20 + 1.30 + 1.30 = 3.80$ lbs/ft. Therefore; 50 lbs (the maximum capacity for an FNW 7701) divided by 3.80 lbs/ft = 13.16 ft for the maximum spacing using the figure 7701; however maximum recommended spacing is 10 feet between supports so the support blocks should be spaced at 10 foot intervals on straight runs and within 2 feet of any change of direction. All piping should be supported within 3 feet of each outlet box, cabinet, or fitting.

EXAMPLE #2: If you have a 2" Conduit which is filled 75% - 100% with conductor and two 1" Conduits that are filled 25% - 50% with conductor, you have $8.50 + 1.30 + 1.30 = 11.10$ lbs/ft. Therefore; 50 lbs (the maximum capacity for an FNW 7701) divided by 11.10 lbs/ft = 4.50 ft for the maximum spacing using the figure 7701 and within 2 feet of any change of direction. All piping should be supported within 3 feet of each outlet box, cabinet, or fitting.

MAXIMUM RECOMMENDED SPACING BETWEEN BLOCKS IS 10 FEET

All units are Pounds Per Foot (lbs./ft.)

CONDUIT SIZE (Nominal)	Weight / Ft of Conduit Empty	Maximum Weight / Ft Of Conduit & Conductor	WHEN CONDUIT IS UP TO 25% FULL	WHEN CONDUIT IS 25%-50% FULL	WHEN CONDUIT IS 50%-75% FULL	WHEN CONDUIT IS 75%-100% FULL
1/2"	0.85	1.20	0.30	0.60	0.90	1.20
3/4"	1.13	1.80	0.45	0.90	1.35	1.80
1"	1.68	2.60	0.65	1.30	1.95	2.60
1-1/4"	2.28	4.30	1.08	2.15	3.23	4.30
1-1/2"	2.73	5.90	1.48	2.95	4.43	5.90
2"	3.68	8.50	2.13	4.25	6.38	8.50
2-1/2"	5.82	11.50	2.88	5.75	8.63	11.50
3"	7.62	16.50	4.13	8.25	12.38	16.50
3-1/2"	9.20	19.00	4.75	9.50	14.25	19.00
4"	10.89	24.80	6.20	12.40	18.60	24.80
5"	14.81	35.90	8.98	17.95	26.93	35.90
6"	19.19	50.70	12.68	25.35	38.03	50.70

LOAD CALCULATION CHART

PIPE APPLICATIONS USING STEEL PIPE & COPPER TUBING

HOW TO USE THE CHART

APPLICATION: Choose the appropriate pipe size and media fill type. The chart indicates the weight per foot of pipe and fill type. To choose the proper number of pipe supports, simply divide the cumulative weight per foot by the maximum capacity of the support. (Refer to the submittal sheets for the maximum loading capacities.)

EXAMPLE #1: If you have a 1-1/2" type K water filled copper tube and two 1/2" schedule 40 gas filled steel pipes, you have $2.11 + 0.85 + 0.85 = 3.81$ lbs/ft. Therefore; 50 lbs (the maximum capacity for an FNW 7701) divided by 3.81 lbs/ft = 13.12 ft for the maximum spacing using the figure 7701; however maximum recommended spacing is 10 feet between supports so the support blocks should be spaced at 10 foot intervals on straight runs and within 2 feet of any change of direction. All piping should be supported within 3 feet of each outlet box, cabinet, or fitting.

EXAMPLE #2: If you have a 3" type L water filled copper tube and two 1/2" schedule 40 gas filled steel pipes, you have $6.26 + 1.09 + 1.09 = 8.44$ lbs/ft. Therefore; 50 lbs (the maximum capacity for an FNW 7701) divided by 8.44 lbs/ft = 5.9 ft for the maximum spacing using the figure 7701 and within 2 feet of any change of direction. All piping should be supported within 3 feet of each outlet box, cabinet, or fitting.

MAXIMUM RECOMMENDED SPACING BETWEEN BLOCKS IS 10 FEET

All units are Pounds Per Foot (lbs./ft.)

PIPE SIZE (Nominal)	Sch 40 Steel Pipe Gas Filled	Sch 40 Steel Pipe Water Filled	Sch 80 Steel Pipe Gas Filled	Sch 80 Steel Pipe Water Filled	Type L Copper Gas Filled	Type L Copper Water Filled	Type K Copper Gas Filled	Type K Copper Water Filled
1/2"	0.85	0.98	1.09	1.19	0.29	0.39	0.34	0.44
3/4"	1.13	1.36	1.47	1.66	0.46	0.67	0.64	0.83
1"	1.68	2.05	2.17	2.48	0.66	1.01	0.84	1.18
1-1/4"	2.27	2.92	3.00	3.56	0.88	1.43	1.04	1.57
1-1/2"	2.72	3.60	3.63	4.40	1.14	1.89	1.36	2.11
2"	3.65	5.10	5.02	6.30	1.75	3.09	2.06	3.36
2-1/2"	5.79	7.86	7.66	9.49	2.48	4.54	2.93	4.93
3"	7.58	10.78	10.25	13.11	3.33	6.26	4.00	6.87
3-1/2"	9.11	13.40	12.51	16.36	4.29	8.28	5.12	9.05
4"	10.79	16.31	14.98	19.96	5.38	10.56	6.51	11.56
5"	14.62	23.29	20.78	28.66	7.61	15.70	9.67	17.53
6"	18.98	31.49	28.57	39.86	10.20	21.81	13.90	25.13

TYPICAL ROOFTOP INSTALLATION

1. Piping should be attached using standard strut clamps and accessories suitable for 13/16" strut.
2. To distribute weight evenly, center the load on the support.
3. Piping should be supported within two feet of each change of piping direction or within the maximum calculated support spacing, whichever is less.
4. All piping should be supported within three feet of each outlet box, cabinet or fitting or within the maximum calculated support spacing, whichever is less.
5. The maximum load per FNW 7701 pipe support is 50 pounds.
6. The recommended maximum spacing between pipe supports is ten feet.

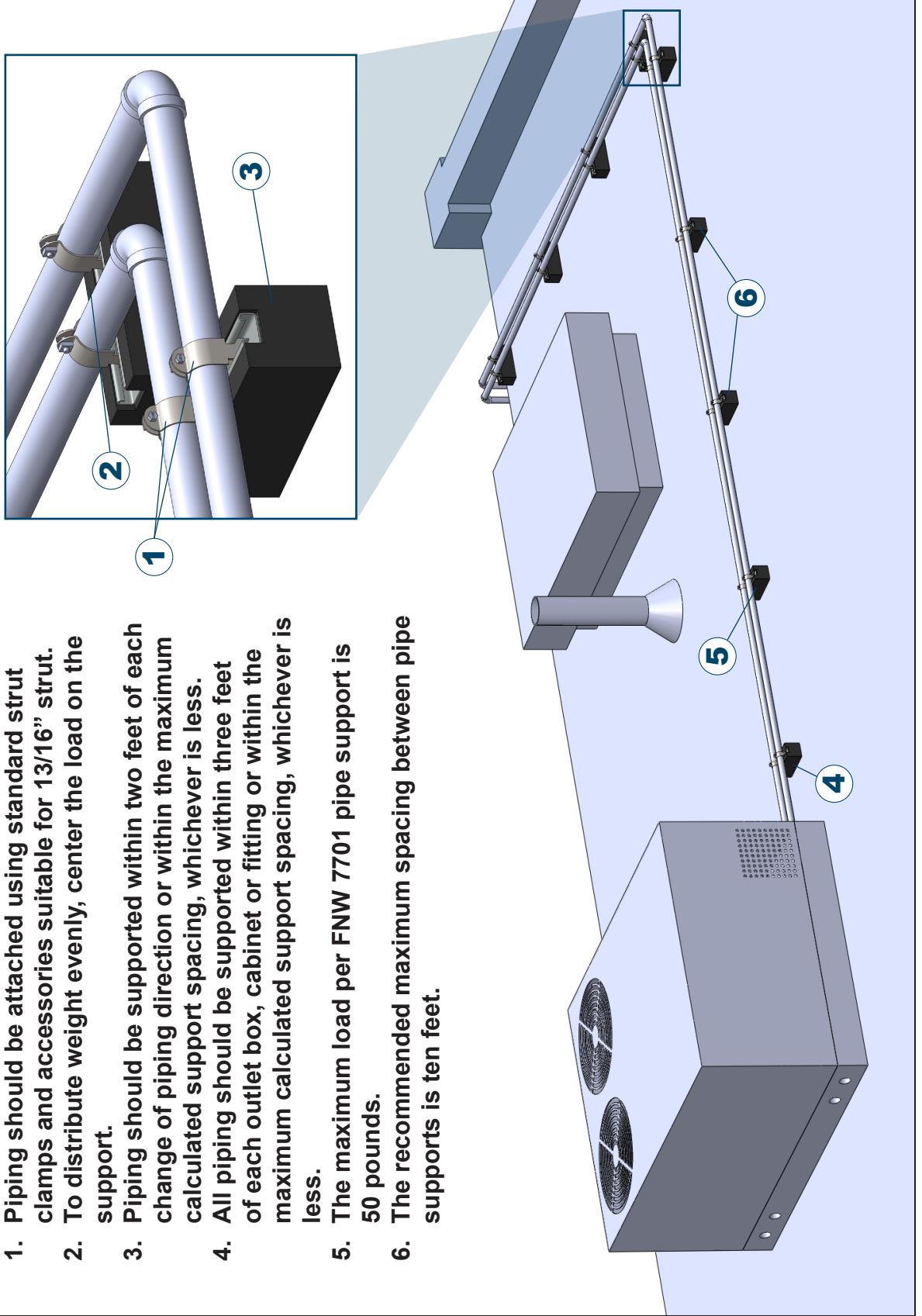

TYPICAL EXPANSION LOOP INSTALLATION

1. When long runs of pipe are necessary, an expansion loop should be added to compensate for pipe thermal expansion and contraction movement.
2. Piping should be supported within two feet of each change of piping direction or within the maximum calculated support spacing, whichever is less.
3. The maximum load per FNW 7701 pipe support is 50 pounds.
4. The recommended maximum spacing between pipe supports is ten feet.
5. Piping should be attached using standard strut clamps and accessories suitable for 13/16" strut.
6. To distribute weight evenly, center the load on the support.

